

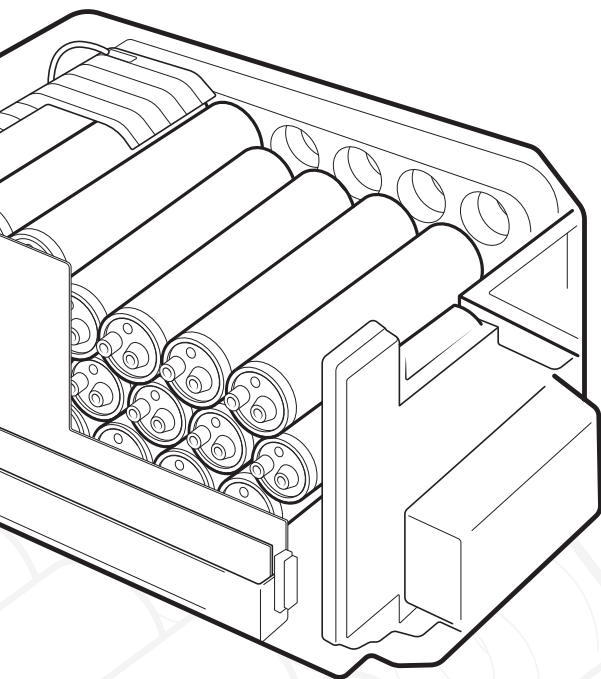

ENVIROSTREAM AUSTRALIA

# On-shore Battery Recycling Solution



## ENVIROSTREAM STORY

Envirostream Australia was created in 2017 to develop safe and innovative management solutions for one of the biggest emerging challenges for the Australian waste stream — batteries. With almost two decades' experience in the resource recovery industry, we know firsthand that the practice of shipping batteries offshore can have detrimental environmental impacts and put human safety at risk.

And this issue isn't going away. Recent reports indicate that the number of lithium batteries entering the waste stream will **grow by at least 300% each year** by 2036.

So we set out to create safe, efficient waste management solutions for batteries in Australia — and Envirostream was born.

## ENVIROSTREAM SOLUTION

Here at Envirostream, we are leading the innovation charge with new battery processing methods. Our Australian-owned, enclosed battery processing facility in Victoria is based on international best practice, designed and built by the team at Envirostream.

The facility is equipped to recover the resources from batteries — right here in Australia. Our modular, automated processing system can safely recover more than 95% of the resources from end-of-life batteries. We send those resources to metal and battery manufacturers, where they can be used as raw materials in new batteries.

The result: a truly circular economy.

As a proud Member of the Australian Battery Recycling Initiative, we offer cost-effective, tailored solutions to manage battery collection, transport, sorting and processing. With Envirostream, there's no need for batteries to leave Australia or go to landfill.

Envirostream Australia Pty Ltd

E. [info@envirostream.com.au](mailto:info@envirostream.com.au)

P. 03 9357 5346

[www.envirostream.com.au](http://www.envirostream.com.au)





**ENVIROSTREAM SYSTEM**

The revolutionary Envirostream system is the result of two years of research and development. Our ISO 14001 accredited, modular processing technology can process 40 tonnes per line, per month. We operate two dedicated, enclosed processing lines that can process 80 tonnes of batteries per month combined. Making expansion easy, we constructed the Envirostream system with efficiency in mind. The modular design lets us carry out line maintenance without compromising our processing ability and can be placed anywhere in Australia. For mixed consignments, we have developed an effective battery sorting solution. At Envirostream, we're one step ahead.

